

# Hydraulic/step type

## HLH Bellows

Load capacity: 265 to 882 lb



HLH-120J



Standard type is equipped with bellows which improves worker safety and prevents accidents.

### Major features of the HLH Series

- Hydraulic cylinder
- Casters with brakes (double stopper for models other than HLH-120J)
- Foot pedal type
- Comes with an overloading prevention device \*1
- Bellows type full cover
- Comes with a rapid traverse device (changes by approximately 20% of the load \*2)
- Has a springback mechanism in the release handle. Lowering will immediately stop as soon as you release the handle.

### Option

- Pump with a rapid traverse device

### Major specifications

Oil used	Turbine oil: ISO VG22
Materials	Bellows : Acrylic resin coated polyester fabric Pump : Urethane type resin spray painting Cylinder : Urethane type resin spray painting Main body : Baked melamine / Powder coating

\*1 The lifter will not elevate when overloaded.

\*2 This is optional depending on the model. See the specification table for details.

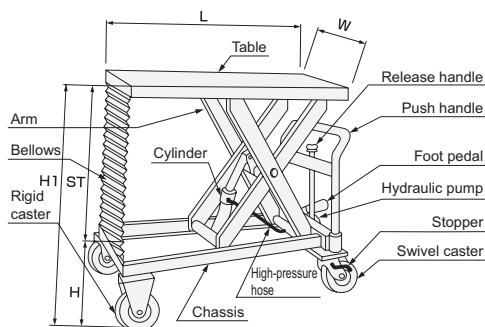

Unit: inch

	Model	Load capacity	Table dimensions W x L	Stroke (ST)	Table height (H to H1)	Overall length (LL)	Wheels	Number of pedals Rapid traverse / Standard	Deadweight
Bellows	HLH-120J	265 lb	20.5×33.5	19	9.3 to 28.3	41.7	φ3.9 rubber	-/18	99 lb
	HLH-200J	441 lb	23.6×37.4	21.3	10.4 to 31.7	45.7	φ3.9 rubber	-/28	148 lb
	HLH-400MJ	882 lb	23.6×41.3	23.6	13 to 36.6	50	φ5.9 rubber	18/42	216 lb